

WEST WINDSOR TOWNSHIP
EAST WINDSOR TOWNSHIP

BLOCK 4
LOT 2
AURORBINO PHARMA USA INC.
AREA - 25,920 S.F./3.59 AC.
DB 2282, PG 935

BLOCK 37,01
AURORBINO PHARMA USA INC.
AREA - 149,279 S.F./3.427 AC.
DB 2282, PG 935

BLOCK 87
LOT 28
AURORBINO PHARMA USA INC.
AREA - 1,096,319 S.F./25.168 AC.
DB 2282, PG 935

GRAPHIC SCALE 1" = 100'

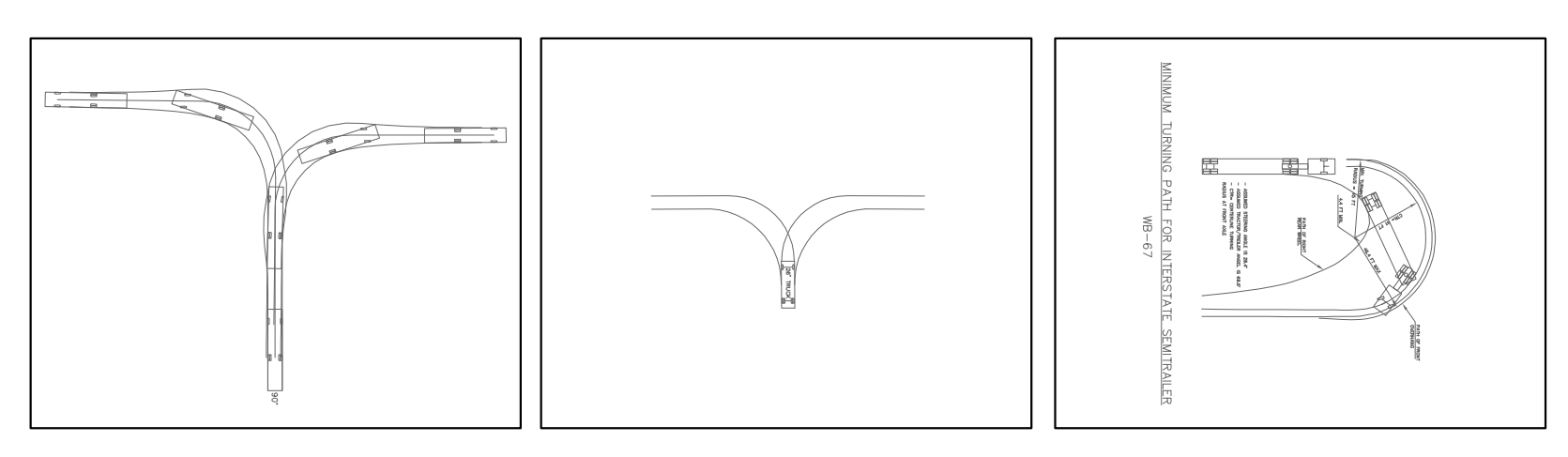

TRUCK MOVEMENT LAYOUT

WB-67 TRUCK

26' DELIVERY TRUCK

SU-47 FIRE TRUCK

2	REVISED AS PER EAST WINDSOR TOWNSHIP LETTER DATED 07-27-18.	08-03-18
1	DESIGN	03-15-18
0	REVISION	01-15-18

CLIENT:
AURORBINO PHARMA USA INC.
279 PRINCETON-HIGHTSTOWN ROAD
EAST WINDSOR, NJ 08820

MEH CONSULTING ENGINEERS, INC.
CIVIL ENGINEERS - STRUCTURAL ENGINEERS
ENVIRONMENTAL AND HYDRAULIC ENGINEERS
825 BLOOMFIELD AVENUE SUITE 105
VERONA, NEW JERSEY 07044
PHONE: (973) 289-2000 FAX: (973) 289-4888

PROPOSED 3,771,100 S.F. OFFICE/WAREHOUSE BUILDING
AURORBINO PHARMA USA, INC.
TOWNSHIP OF EAST WINDSOR, LOT 2, BLOCK 4
MEMBER COUNTY, NEW JERSEY

DATE: 08-03-18
SCALE: AS SHOWN
DRAWN BY: BHS SHEHET
CHECKED BY: MEH

NO.: 18-012 CADD FILE: Y3M14

Y-14